

# **FnIO M – Series :**

## ***M1418***

***M1418(8 Channels, Sink Input / 8 channels Source Output with Diagnostic, 24Vdc)***

Date: 2019.09.23

---

## Table of Contents

<a href="#">Table of Contents.....</a>	<a href="#">2</a>
<a href="#">History.....</a>	<a href="#">3</a>
<a href="#">1.ENVIRONMENT SPECIFICATION.....</a>	<a href="#">4</a>
<a href="#">2.M1418 (8 Sink Input / 8 Source Output with Diagnostic, 24Vdc).....</a>	<a href="#">5</a>
<a href="#">2.1.M1418 Specification .....</a>	<a href="#">5</a>
<a href="#">2.2.M1418 Wiring Diagram.....</a>	<a href="#">6</a>
<a href="#">2.3.M1418 LED Indicator.....</a>	<a href="#">7</a>
<a href="#">2.3.1.LED Indicator.....</a>	<a href="#">7</a>
<a href="#">2.3.2.Channel Status LED.....</a>	<a href="#">7</a>

## History

REV.	PAGES	REMARKS	DATE	Editor
Preliminary		Preliminary	Sept. 23, 2019	BS, HA
1.01		Image, UL Spec, Torque, Hotswap Function	2020/04/21	CW SEO
1.02		Vibration specification, Product certification changed	2020/04/27	CW SEO
1.03	10~14	Added ATEX certificate	2020/05/07	CW SEO
1.04	7	Delete LED Off state	2020/05/27	CW SEO
1.05	6	Input specification changed	2020/07/09	BS HA
1.06		Remove Description pages of Hot Swap Function, Use in Hazardous Environments and Caution	2020/12/08	SJ LIM

## 1. ENVIRONMENT SPECIFICATION

<b>Environmental specification</b>	
Operating Temperature	-25°C~60°C
UL Temperature	-20°C~60°C
Storage Temperature	-40°C~85°C
Relative Humidity	5% ~ 90% non-condensing
Mounting	DIN rail

<b>General specification</b>	
Shock Operating	IEC 60068-2-27
Vibration Resistance	Based on IEC 60068-2-6 DNVGL-CG-0039 : Vibration Class B, 4g
Industrial Emissions	EN 61000-6-4/A11 : 2011
Industrial Immunity	EN 61000-6-2 : 2005
Installation Position	Vertical and horizontal installation is available.
Product Certifications	CE, UL, FCC, DNV, ATEX

## 2. M1418 (8 Sink Input / 8 Source Output with Diagnostic, 24Vdc)

### 2.1. M1418 Specification

Items	Specification
<b>Input Specification</b>	
Input per module	8 Points Sink type
Indicators	8 Green input state
ON-state Voltage	24V dc nominal Min. 9Vdc to Max. 28.8Vdc
OFF-state voltage	6Vdc @ 25°C
ON-state current	5.75mA maximum/point @28.8Vdc
Input Signal Delay	OFF to ON : 0.2ms Max ON to OFF : 0.3ms Max
Input filter	Adjustable, up to 10ms
Nominal Input Impedance	14.8K ohm typical
<b>Output Specification</b>	
Output per module	8 Points Source type
Indicators (Logic side)	8 Green output state
Output Voltage Range	Nominal 24Vdc, Min. 15Vdc to Max. 28.8Vdc
ON-state voltage drop	Max. 0.5Vdc @ -25°C ~ 60°C,
Field Power OFF-state voltage	5.0Vdc @ 25°C
ON-State Min. Current	1mA per channel
OFF-State Leakage current	Max. 10uA
Output Signal Delay	OFF to ON : 0.1ms maximum ON to OFF : 0.3ms maximum
Output Current Rating	Max. 0.5A per channel / Max. 4A per unit
Output Protection (NCV8461DR2G/SO8)	Over Current limit : 1.9A@ 25°C per each channels Thermal Shutdown : 175°C Short circuit protection
<b>General specification</b>	
Power dissipation	45mA maximum @ 5.0Vdc
Isolation	I/O to Logic : Photocoupler Isolation
UL Field Power	Supply voltage : 24Vdc nominal, Class 2
Field Power	Supply voltage : 24Vdc nominal Voltage range : 15~28.8Vdc Power dissipation : 55mA @ 24Vdc
Single Wire	0.205mm - 1.3mm (24-16 AWG)
Torque	0.8Nm(7 lb-in)
Weight	72g
Module Size	12mm x 110mm x 72mm
Hot Swap	Possible
<b>Environment Condition</b>	<b>Refer to 'Environment Specification'</b>

\* Class 2, adjacent to voltage rating (30Vmax)

## 2.2. M1418 Wiring Diagram

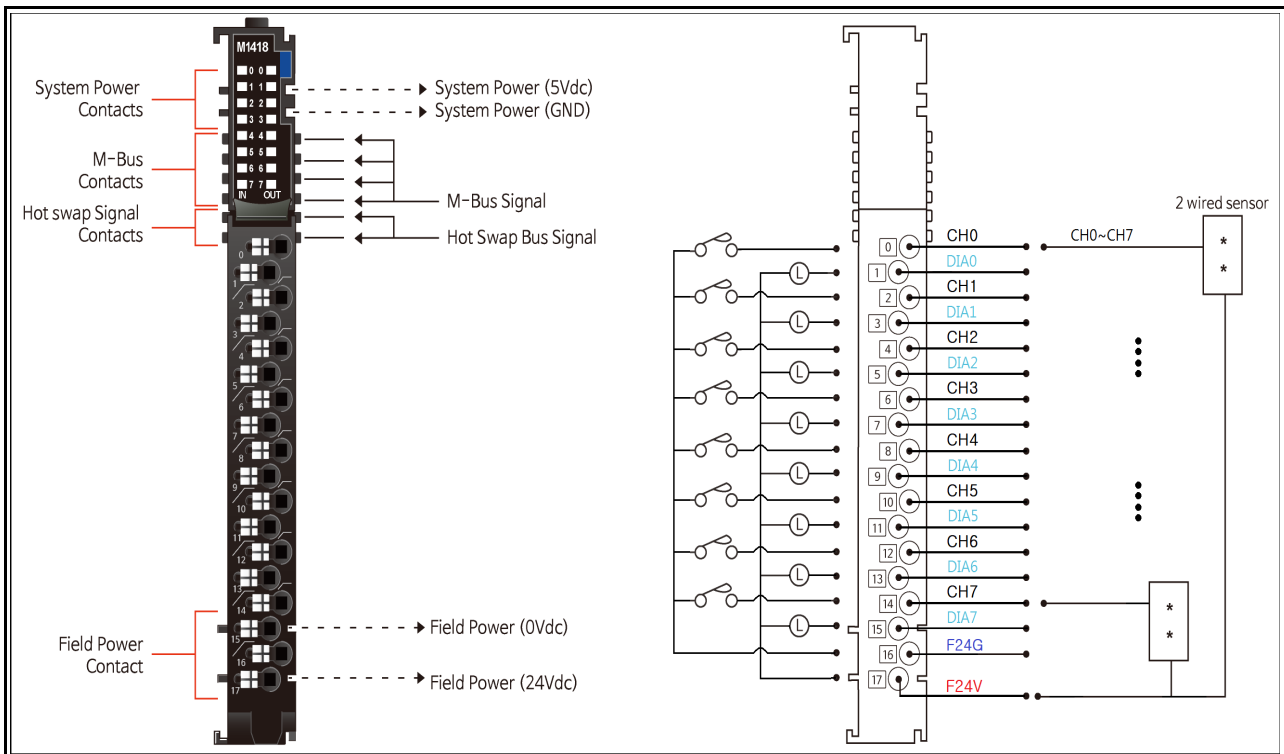

Pin No.	Signal Description
0	Input Channel 0
1	Diagnostic Output Channel 0
2	Input Channel 1
3	Diagnostic Output Channel 1
4	Input Channel 2
5	Diagnostic Output Channel 2
6	Input Channel 3
7	Diagnostic Output Channel 3
8	Input Channel 4
9	Diagnostic Output Channel 4
10	Input Channel 5
11	Diagnostic Output Channel 5
12	Input Channel 6
13	Diagnostic Output Channel 6
14	Input Channel 7
15	Diagnostic Output Channel 7
16	Common (Field Power 0V)
17	Common (Field Power 24V)

Series No	Through Air	Over Surface	CTI
RTB18C	1.5mm	1.5mm	175≤CTI≤400

Spacings : The following minimum spacing in inches (millimeters) shall be maintained between uninsulated live parts of opposite polarity; and between an uninsulated live part and a grounded part including any mounting surface or exposed metal part.

## 2.3. M1418 LED Indicator

### 2.3.1. LED Indicator

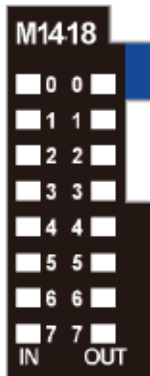

LED No.	LED Function / Description	LED Color
0(Left side)	INPUT Channel 0	Green
1	INPUT Channel 1	Green
2	INPUT Channel 2	Green
3	INPUT Channel 3	Green
4	INPUT Channel 4	Green
5	INPUT Channel 5	Green
6	INPUT Channel 6	Green
7	INPUT Channel 7	Green
0(Right side)	OUTPUT Channel 0	Green
1	OUTPUT Channel 1	Green
2	OUTPUT Channel 2	Green
3	OUTPUT Channel 3	Green
4	OUTPUT Channel 4	Green
5	OUTPUT Channel 5	Green
6	OUTPUT Channel 6	Green
7	OUTPUT Channel 7	Green

### 2.3.2. Channel Status LED

- LED No. 0~7 (Left side)

Status	LED	To indicate
Not Signal	Off	Normal Operation
On Signal	Green	Normal Operation

- LED No. 0~7 (Right side)

Status	LED	To indicate
Not Signal	Off	Normal Operation
On Signal	Green	Normal Operation
Channel Fault	Flashing Green	Short to GND(On State)
		Overcurrent
		Overtemperature

### 2.3.3. Mapping data into the image table

- Input Module Data

D7	D6	D5	D4	D3	D2	D1	D0
D15	D14	D13	D12	D11	D10	D9	D8

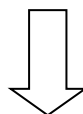

- Input Image Value

Bit No	Bit7	Bit6	Bit5	Bit4	Bit3	Bit2	Bit1	Bit0
Byte0	D7	D6	D5	D4	D3	D2	D1	D0
Byte1	D15	D14	D13	D12	D11	D10	D9	D8

● **Output Image Value**

Bit No	Bit7	Bit6	Bit5	Bit4	Bit3	Bit2	Bit1	Bit0
Byte0	D7	D6	D5	D4	D3	D2	D1	D0

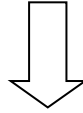

● **Output Module Data**

D7	D6	D5	D4	D3	D2	D1	D0
----	----	----	----	----	----	----	----

## 2.4 Parameter Data

- Valid Parameter length: 4 Bytes
- Parameter Data

Bit No	Bit7	Bit6	Bit5	Bit4	Bit3	Bit2	Bit1	Bit0
Byte0	Fault Action (ch0~ch7) 0: Fault value, 1:Hold last state							
Byte1	Fault value (ch0~ch7) 0:Off, 1:On							
Byte2	Input Filter value : 0 ~ 10 (unit : ms)							
Byte3	Reserved							