

# **FnIO M – Series :**

***M226F***

***M226F(16 Channels, Source Output Terminal, 24Vdc/0.3A)***

---

## Table of Contents

<a href="#">Table of Contents.....</a>	<a href="#">2</a>
<a href="#">History.....</a>	<a href="#">3</a>
<a href="#">1.ENVIRONMENT SPECIFICATION.....</a>	<a href="#">4</a>
<a href="#">2.M226F (16 Channels Source Output Terminal).....</a>	<a href="#">5</a>
<a href="#">2.1.M226F Specification.....</a>	<a href="#">5</a>
<a href="#">2.2.M226F Wiring Diagram.....</a>	<a href="#">6</a>
<a href="#">2.3.M226F LED Indicator.....</a>	<a href="#">7</a>
<a href="#">2.3.1.LED Indicator.....</a>	<a href="#">7</a>
<a href="#">2.3.2.Channel Status LED.....</a>	<a href="#">7</a>
<a href="#">2.4.Mapping data into the image table.....</a>	<a href="#">8</a>
<a href="#">2.5.Parameter Data.....</a>	<a href="#">8</a>

## History

REV.	PAGES	REMARKS	DATE	Editor
-		Preliminary	2018/6/18	BS HA
1.00			2018/11/14	YM KIM
1.01		Image, UL Spec, Torque, Hotswap Function	2020/04/21	CW SEO
1.02		Vibration specification, Product certification changed	2020/04/27	CW SEO
1.03	10~14	Added ATEX certificate	2020/05/07	CW SEO
1.04		Remove Description pages of Hot Swap Function, Use in Hazardous Environments and Caution(Before using the unit)	2020/12/08	SJ LIM
1.05	5	Power dissipation changed	2021/04/13	BS HA

## 1. ENVIRONMENT SPECIFICATION

<b>Environmental specification</b>	
Operating Temperature	-25℃~60℃
UL Temperature	-20℃~60℃
Storage Temperature	-40℃~85℃
Relative Humidity	5% ~ 90% non-condensing
Mounting	DIN rail
<b>General specification</b>	
Shock Operating	IEC 60068-2-27
Vibration Resistance	Based on IEC 60068-2-6 DNVGL-CG-0039 : Vibration Class B, 4g
Industrial Emissions	EN 61000-6-4/A11 : 2011
Industrial Immunity	EN 61000-6-2 : 2005
Installation Position	Vertical and horizontal installation is available.
Product Certifications	CE, UL, FCC, KR, ABS, DNV, ATEX

## 2. M226F (16 Channels Source Output Terminal)

### 2.1. M226F Specification

Items	Specification
<b>Input Specification</b>	
Output per module	16 channels Source type
Indicators	16 Green output state
Output Voltage Range	Nominal 24Vdc, Min. 15Vdc ~ Max. 28.8Vdc
ON-state voltage drop	Max. 0.3Vdc @ 25°C / 0.5Vdc@ 60°C
ON-State Min. Current	1mA per channel
OFF-State Leakage current	Max. 5uA
Output Signal Delay	OFF to ON : 0.3mS maximum ON to OFF : 0.3mS maximum
Output Current Rating	Max. 0.3A per channel / Max. 4.8A per unit
Protection (ITS716G)	Over Current limit : Min 6.5A@ 25°C per each channels(ITS716G) Thermal Shutdown : Min 4A@ 25°C per each channels (ITS716G, Min 150°C) Short circuit protection
COMMON Type	16 channels / 2COM (Single Common)
<b>General specification</b>	
Power dissipation	40mA maximum @ 5.0Vdc
Isolation	I/O to Logic : Photocoupler isolation
UL Field Power	Supply voltage : 24Vdc nominal, Class 2
Field Power	Supply voltage : Class 2, 24Vdc nominal Voltage range : 15~28.8Vdc Power dissipation: 45mA maximum @ 28.8Vdc
Single Wire	0.205mm <sup>φ</sup> - 1.3mm <sup>φ</sup> (24-16 AWG)
Torque	0.8Nm(7 lb-in)
Weight	72g
Module Size	12mm x 110mm x 75mm
Hot Swap	Possible
<b>Environment Condition</b>	<b>Refer to '1. Environment Specification'</b>

\* Class 2, adjacent to voltage rating (30Vmax)

## 2.2. M226F Wiring Diagram

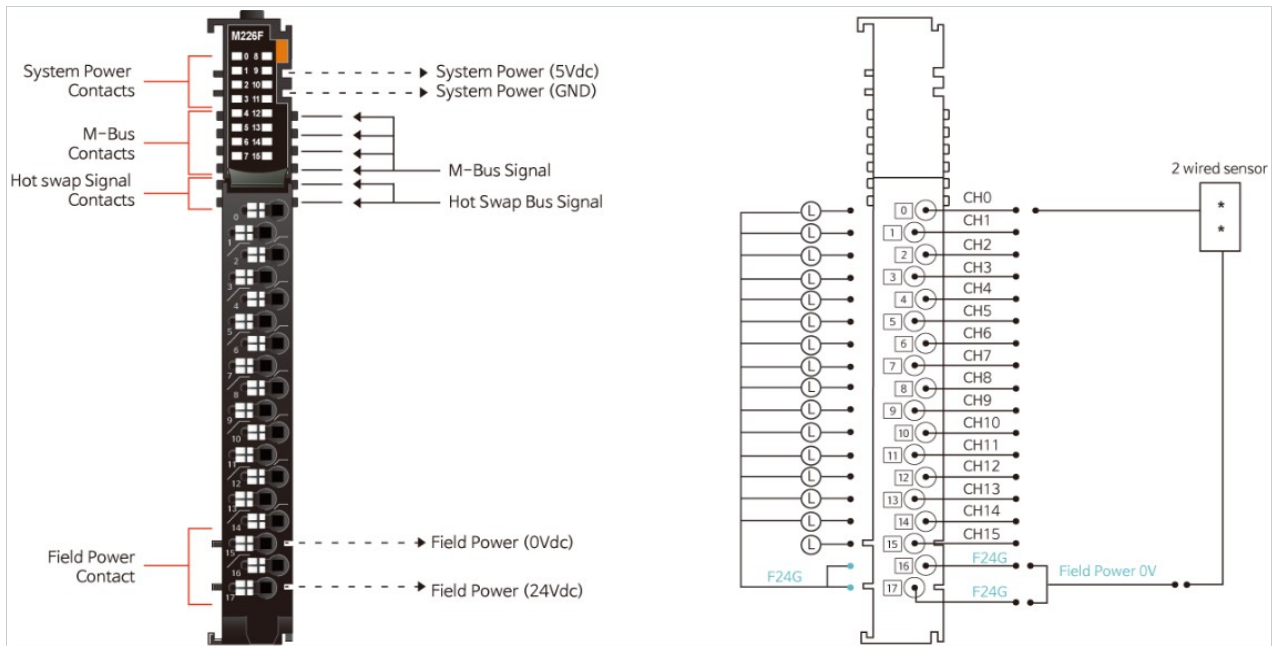

Pin No.	Signal Description
0	Output Channel 0
1	Output Channel 1
2	Output Channel 2
3	Output Channel 3
4	Output Channel 4
5	Output Channel 5
6	Output Channel 6
7	Output Channel 7
8	Output Channel 8
9	Output Channel 9
10	Output Channel 10
11	Output Channel 11
12	Output Channel 12
13	Output Channel 13
14	Output Channel 14
15	Output Channel 15
16	Common (Field Power 0V)
17	Common (Field Power 0V)

Series No	Through Air	Over Surface	CTI
RTB18C	1.5mm	1.5mm	175≤CTI≤400

Spacings : The following minimum spacing in inches (millimeters) shall be maintained between uninsulated live parts of opposite polarity; and between an uninsulated live part and a grounded Part including any mounting surface or exposed metal part.

## 2.3. M226F LED Indicator

### 2.3.1. LED Indicator

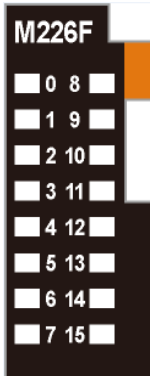

LED No.	LED Function / Description	LED Color
0	OUTPUT Channel 0	Green
1	OUTPUT Channel 1	Green
2	OUTPUT Channel 2	Green
3	OUTPUT Channel 3	Green
4	OUTPUT Channel 4	Green
5	OUTPUT Channel 5	Green
6	OUTPUT Channel 6	Green
7	OUTPUT Channel 7	Green
8	OUTPUT Channel 8	Green
9	OUTPUT Channel 9	Green
10	OUTPUT Channel 10	Green
11	OUTPUT Channel 11	Green
12	OUTPUT Channel 12	Green
13	OUTPUT Channel 13	Green
14	OUTPUT Channel 14	Green
15	OUTPUT Channel 15	Green

### 2.3.2. Channel Status LED

Status	LED	To indicate
Not Signal	Off	Normal Operation
On Signal	Green	Normal Operation

## 2.4. Mapping data into the image table

- **Output Image Value**

Bit No	Bit7	Bit6	Bit5	Bit4	Bit3	Bit2	Bit1	Bit0
Byte0	D7	D6	D5	D4	D3	D2	D1	D0
Byte1	D15	D14	D13	D12	D11	D10	D9	D8

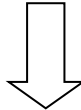

- **Output Module Data**

D7	D6	D5	D4	D3	D2	D1	D0
D15	D14	D13	D12	D11	D10	D9	D8

## 2.5. Parameter Data

- **Valid Parameter length: 4 Bytes**
- **Parameter Data**

Bit No	Bit7	Bit6	Bit5	Bit4	Bit3	Bit2	Bit1	Bit0
<b>Byte0</b>	Fault Action (ch0~ch7) 0: Fault value, 1:Hold last state							
<b>Byte1</b>	Fault Action (ch8~ch15) 0: Fault value, 1:Hold last state							
<b>Byte2</b>	Fault value (ch0~ch7) 0:Off, 1:On							
<b>Byte3</b>	Fault value (ch8~ch15) 0:Off, 1:On							