

FnIO M – Series :

M2418

M2418(8 Channels, Sink Output With Diagnostics, 24Vdc/0.5A)

Date: 2019.09.23

Table of Contents

Table of Contents.....	2
History.....	3
1.ENVIRONMENT SPECIFICATION.....	4
2.M2418 (8 Channels Sink Output with Diagnostics).....	5
2.1.M2418 Specification.....	5
2.2.M2418 Wiring Diagram.....	6
2.3.M2418 LED Indicator.....	7
2.3.1.LED Indicator.....	7
2.3.2.Channel Status LED.....	7
2.4.Mapping data into the image table.....	8
2.5.Parameter Data.....	8

History

REV.	PAGES	REMARKS	DATE	Editor
Preliminary		Preliminary	Sept. 23, 2019	BS, HA
1.01		Image, Torque, Hotswap Function	2020/04/21	CW SEO
1.02		Vibration specification, Product certification changed	2020/04/27	CW SEO
1.03	10~14	Added ATEX certificate	2020/05/07	CW SEO
1.04	5, 7	Changed Output specification, Channel Status LED	2020/07/13	BS, HA
1.05		Remove Description pages of Hot Swap Function, Use in Hazardous Environments and Caution(Before using the unit)	2020/12/08	SJ LIM

1. ENVIRONMENT SPECIFICATION

Environmental specification	
Operating Temperature	-25 °C~60 °C
UL Temperature	-20 °C~60 °C
Storage Temperature	-40 °C~85 °C
Relative Humidity	5% ~ 90% non-condensing
Mounting	DIN rail
General specification	
Shock Operating	IEC 60068-2-27
Vibration Resistance	Based on IEC 60068-2-6 DNVGL-CG-0039 : Vibration Class B, 4g
Industrial Emissions	EN 61000-6-4/A11 : 2011
Industrial Immunity	EN 61000-6-2 : 2005
Installation Position	Vertical and horizontal installation is available.
Product Certifications	CE, UL, FCC, ATEX, DNV

2. M2418 (8 Channels Sink Output with Diagnostics)

2.1. M2418 Specification

Items	Specification
Output specification	
Outputs per module	8 Points, Sink type
Indicators(Logic side)	8 Green Output status, 8 Red diagnostic state
Output Voltage Range	Nominal 24Vdc, Min. 15Vdc to Max. 28.8Vdc
ON-state voltage drop	Max. 0.5Vdc @ -25°C~60°C
ON-State Min. Current	1mA per channel
OFF-State Leakage current	Max. 25uA
Output Signal Delay	OFF to ON : 0.05ms maximum ON to OFF : 0.4ms maximum
Output Current Rating	Max. 0.5A per channel / Max. 4A per unit
Protection (VNS3NV04D)	Over Current limit: Min. 2.8A@ 25°C per each channels Thermal Shutdown : 175°C Short circuit protection
COMMON Type	8 points / 8 COM(Single Common)
General Specification	
Power dissipation	50mA maximum @ 5.0Vdc
Isolation	I/O to Logic : Isolation Field power : Non-isolation
UL Field Power	Supply voltage : 24Vdc nominal, Class 2
Field Power	Supply voltage : 24Vdc nominal Voltage range : 15V - 28.8V Power dissipation: 30mA @24Vdc
Single Wire	0.205mm ² - 1.3mm ² (24-16 AWG)
Torque	0.8Nm(7 lb-in)
Weight	72g
Module Size	12mm x 110mm x 72mm
Hot Swap	Possible
Environment Condition	Refer to 'Environment Specification'

* Class 2, adjacent to voltage rating (30Vmax)

2.2. M2418 Wiring Diagram

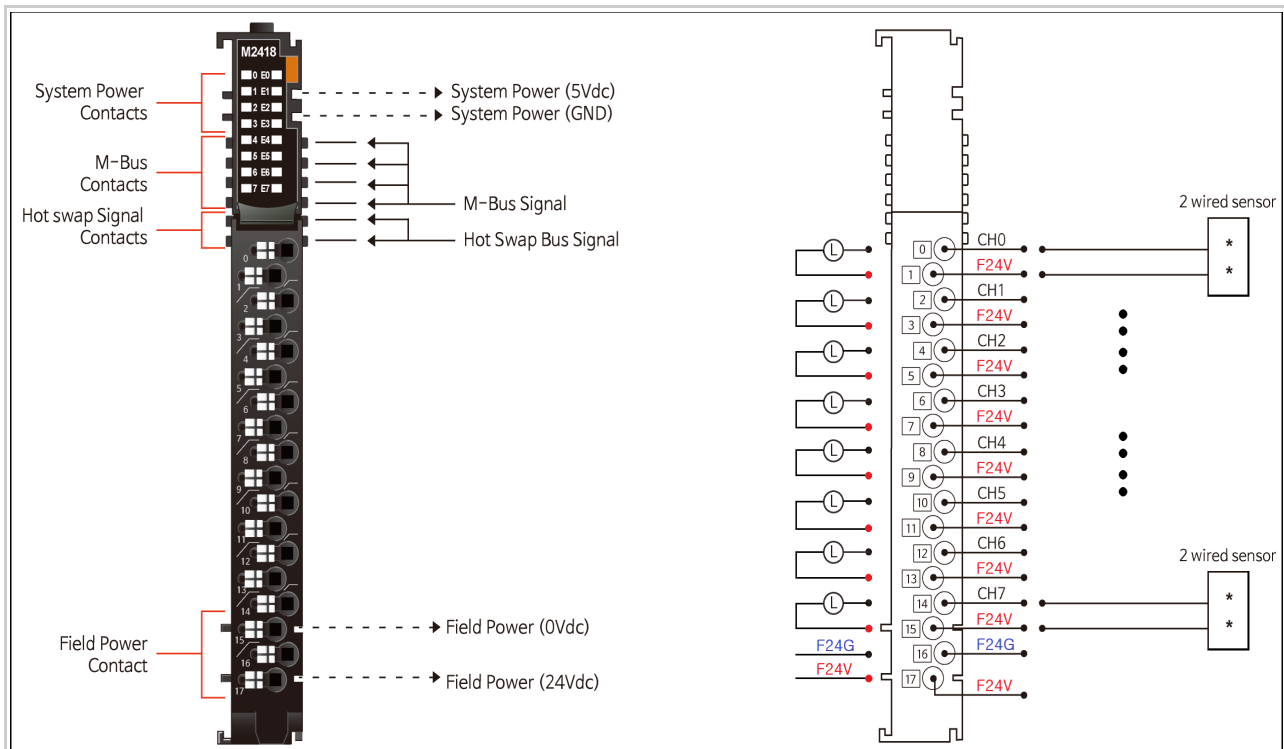

Pin No.	Signal Description
0	Output Channel 0
1	Common (Field Power 24V)
2	Output Channel 1
3	Common (Field Power 24V)
4	Output Channel 2
5	Common (Field Power 24V)
6	Output Channel 3
7	Common (Field Power 24V)
8	Output Channel 4
9	Common (Field Power 24V)
10	Output Channel 5
11	Common (Field Power 24V)
12	Output Channel 6
13	Common (Field Power 24V)
14	Output Channel 7
15	Common (Field Power 24V)
16	Field Power 0V
17	Field Power 24V

Series No	Through Air	Over Surface	CTI
RTB18C	1.5mm	1.5mm	175≤CTI≤400

Spacings : The following minimum spacing in inches (millimeters) shall be maintained between uninsulated live parts of opposite polarity; and between an uninsulated live part and a grounded Part including any mounting surface or exposed metal part.

2.3. M2418 LED Indicator

2.3.1. LED Indicator



LED No.	LED Function / Description	LED Color
0	OUTPUT Channel 0	Green
1	OUTPUT Channel 1	Green
2	OUTPUT Channel 2	Green
3	OUTPUT Channel 3	Green
4	OUTPUT Channel 4	Green
5	OUTPUT Channel 5	Green
6	OUTPUT Channel 6	Green
7	OUTPUT Channel 7	Green
E0	Channel 0 Diagnostic	Red
E1	Channel 1 Diagnostic	Red
E2	Channel 2 Diagnostic	Red
E3	Channel 3 Diagnostic	Red
E4	Channel 4 Diagnostic	Red
E5	Channel 5 Diagnostic	Red
E6	Channel 6 Diagnostic	Red
E7	Channel 7 Diagnostic	Red

2.3.2. Channel Status LED

● LED No. 0~7

Status	LED	To indicate
Not Signal	Off	Normal Operation
On Signal	Green	Normal Operation

● LED No. E0~E7

Status	LED	To indicate
Bus Fault	Red	M-Bus Fault(On State)
Channel Fault	Red	Field Power Off(On State)
		Overtemperature
		Short to VCC(On State)
		Current Limitation

2.4. Mapping data into the image table

- **Output Image Value**

Bit No	Bit7	Bit6	Bit5	Bit4	Bit3	Bit2	Bit1	Bit0
Byte 0	D7	D6	D5	D4	D3	D2	D1	D0

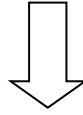

- **Output Module Data**

D7	D6	D5	D4	D3	D2	D1	D0
----	----	----	----	----	----	----	----

- **Input Module Data**

D7	D6	D5	D4	D3	D2	D1	D0
----	----	----	----	----	----	----	----

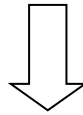

- **Input Image Value**

Bit No	Bit7	Bit6	Bit5	Bit4	Bit3	Bit2	Bit1	Bit0
Byte0	D7	D6	D5	D4	D3	D2	D1	D0

2.5. Parameter Data

- Valid Parameter length: 2 Bytes
- Parameter Data

Bit No	Bit7	Bit6	Bit5	Bit4	Bit3	Bit2	Bit1	Bit0
Byte0	Fault Action (ch0~ch7) 0: Fault value, 1:Hold last state							
Byte1	Fault value (ch0~ch7) 0:Off, 1:On							