

FnIO M – Series :

M4158

M4158 (8 Channels, Current Output, 0~20mA, 16bit)

Table of Contents

Table of Contents.....	2
History.....	3
1.ENVIRONMENT SPECIFICATION.....	4
2.M4158 (8 CHANNELS CURRENT OUTPUT, 0~20mA, 16BIT).....	5
2.1.M4158 Specification.....	5
2.2.M4158 Wiring Diagram.....	6
2.3.M4158 LED Indicator.....	7
2.3.1.LED Indicator.....	7
2.3.2.Channel Status LED.....	7
2.3.3.Data value / Current.....	7
2.5.Mapping data from the image table.....	8
2.6.Parameter Data.....	9

History

REV.	PAGES	REMARKS	DATE	Editor
-	10	New Document	Jan 31, 2020	bs, HA
1.01		Image, Torque, Hotswap Function	2020/04/21	CW SEO
1.02		Vibration specification, Product certification changed	2020/04/27	CW SEO
1.03	11~15	Added ATEX certificate	2020/05/07	BS HA

1. ENVIRONMENT SPECIFICATION

Environmental specification	
Operating Temperature	-25 °C~60 °C
UL Temperature	-20 °C~60 °C
Storage Temperature	-40 °C~85 °C
Relative Humidity	5% ~ 90% non-condensing
Mounting	DIN rail

General specification	
Shock Operating	IEC 60068-2-27
Vibration Resistance	Based on IEC 60068-2-6 DNVGL-CG-0039 : Vibration Class B, 4g
Industrial Emissions	EN 61000-6-4/A11 : 2011
Industrial Immunity	EN 61000-6-2 : 2005
Installation Position	Vertical and horizontal installation is available.
Product Certifications	CE, UL, FCC, ATEX, DNV

2. M4158 (8 CHANNELS CURRENT OUTPUT, 0~20mA, 16BIT)

2.1. M4158 Specification

Items	Specification
Output Specification	
Outputs per module	8 Channels single ended
Indicators(Logic side)	1 Green M-Bus status
Resolution in Ranges	16 bit (Include Sign) 15 bits : 0.61uA/bit
Output Range	0~20mA
Data Format	16bits Integer (2' compliment)
Module Error	±0.1% Full Scale @ 25°C ±0.3% Full Scale @ -25°C, 60°C
Load Resistance	< 200Ω
Dignostic	Field Power Off : Led Blinking Field Power On : Led ON
Conversion Time	Max. 250usec / All channel
Calibration	Not Required
Common Type	8 Common, Field Power 0V is Common(AGND)
General Specification	
Power dissipation	Max. 30mA @ 5.0Vdc
Isolation	I/O to Logic : Photocoupler isolation Field power : Non-Isolation
UL Field Power	Supply voltage : 24Vdc nominal, Class 2
Field Power	Supply Voltage : 24Vdc nominal Voltage Range : 18~28.8Vdc Power Dissipation : Max. 130mA @ 24Vdc
Single Wire	0.205mm ² - 1.3mm ² (24-16 AWG)
Torque	0.8Nm(7 lb-in)
Weight	72g
Module Size	12mm x 110mm x 75mm
Hot Swap	Possible
Environment Condition	Refer to '1. Environment Specification'

* Class 2, adjacent to voltage rating (30Vmax)

2.2. M4158 Wiring Diagram

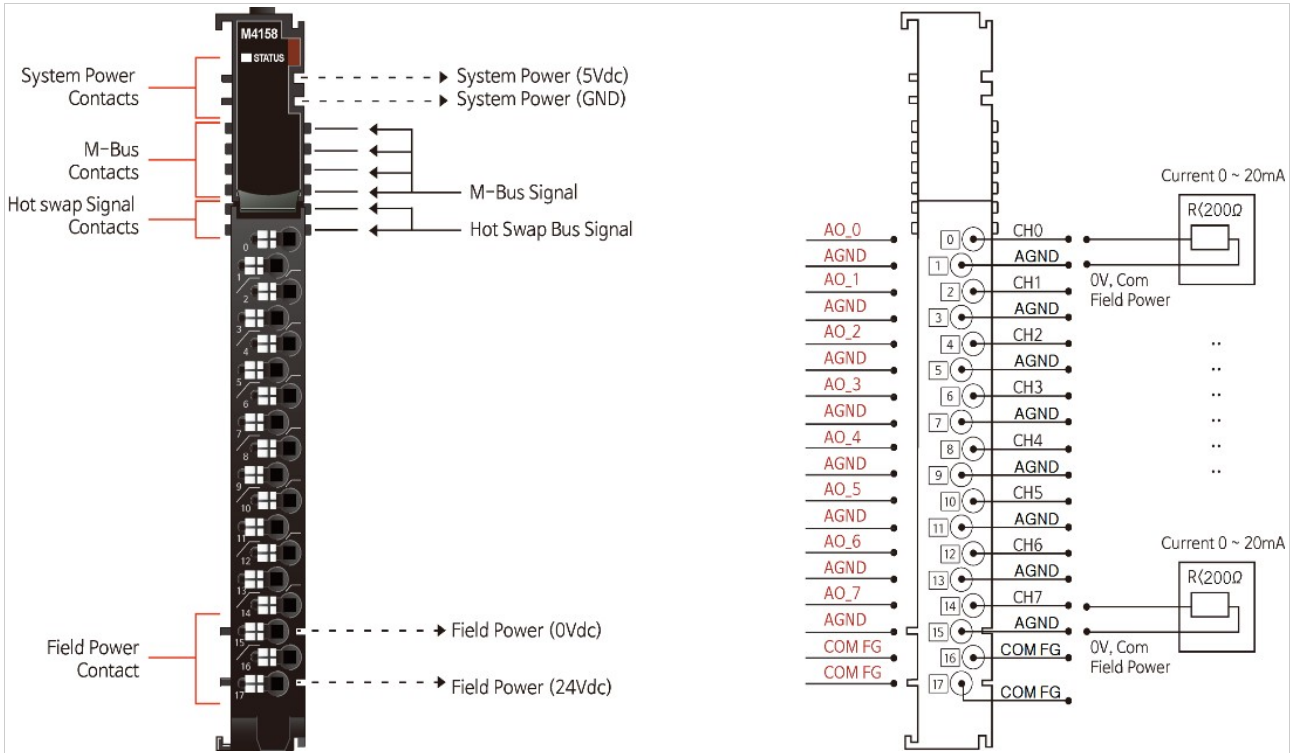

Pin No.	Signal Description
0	Analog Output Channel 0
1	Output Channel Common(AGND)
2	Analog Output Channel 1
3	Output Channel Common(AGND)
4	Analog Output Channel 2
5	Output Channel Common(AGND)
6	Analog Output Channel 3
7	Output Channel Common(AGND)
8	Analog Output Channel 4
9	Output Channel Common(AGND)
10	Analog Output Channel 5
11	Output Channel Common(AGND)
12	Analog Output Channel 6
13	Output Channel Common(AGND)
14	Analog Output Channel 7
15	Output Channel Common(AGND)
16	COM FG
17	COM FG

Series No	Through Air	Over Surface	CTI
RTB18C	1.5mm	1.5mm	175≤CTI≤400

Spacings : The following minimum spacing in inches (millimeters) shall be maintained between uninsulated live parts of opposite polarity; and between an uninsulated live part and a grounded Part including any mounting surface or exposed metal part.

2.3. M4158 LED Indicator

2.3.1. LED Indicator



LED No.	LED Function / Description	LED Color
STATUS	M-bus Status	Green

2.3.2. Channel Status LED

Status	LED	To indicate
M-Bus Status	Off Green	Disconnection Connection
Field Power Error	All Channel Repeat the Green and Off	Field power is unconnected.

2.3.3. Data value / Current

Current	0.0mA	5.0mA	10.0mA	20.0mA
Data(Hex)	H0000	H2000	H4000	H7FFF

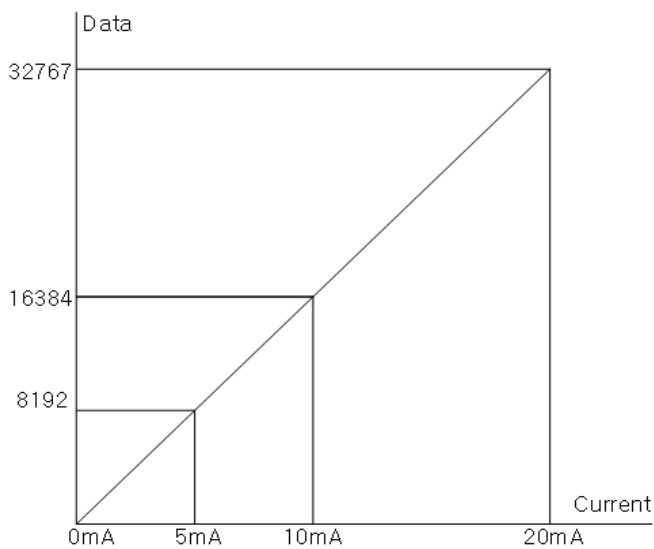

2.4. Mapping data from the image table

- **Output Image Value**

Bit No	Bit7	Bit6	Bit5	Bit4	Bit3	Bit2	Bit1	Bit0
Byte 0	Analog Output Ch0 Low byte							
Byte 1	Analog Output Ch0 High byte							
Byte 2	Analog Output Ch1 Low byte							
Byte 3	Analog Output Ch1 High byte							
Byte 4	Analog Output Ch2 Low byte							
Byte 5	Analog Output Ch2 High byte							
Byte 6	Analog Output Ch3 Low byte							
Byte 7	Analog Output Ch3 High byte							
Byte 8	Analog Output Ch4 Low byte							
Byte 9	Analog Output Ch4 High byte							
Byte 10	Analog Output Ch5 Low byte							
Byte 11	Analog Output Ch5 High byte							
Byte 12	Analog Output Ch6 Low byte							
Byte 13	Analog Output Ch6 High byte							
Byte 14	Analog Output Ch7 Low byte							
Byte 15	Analog Output Ch7 High byte							

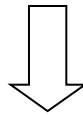

- **Output Module Data -16byte Output Data**

Analog Output Ch0
Analog Output Ch1
Analog Output Ch2
Analog Output Ch3
Analog Output Ch4
Analog Output Ch5
Analog Output Ch6
Analog Output Ch7

2.5. Parameter Data

- Valid Parameter length: 4 Bytes
- Parameter Data

Bit No	Bit7	Bit6	Bit5	Bit4	Bit3	Bit2	Bit1	Bit0
Byte0	Fault Action for channel 3		Fault Action for channel 2		Fault Action for channel 1		Fault Action for channel 0	
	00: Fault Value 01: Hold last state 10: Low Limit 11:High Limit							
Byte1	Fault Action for channel 7		Fault Action for channel 6		Fault Action for channel 5		Fault Action for channel 4	
	00: Fault Value 01: Hold last state 10: Low Limit 11:High Limit							
Byte2	Fault Value Low Byte							
Byte3	Fault Value High Byte							