

FnIO M - Series:

M9287

M9287 Profinet Network Adapter (Single Type)



Table of Contents

Table of Contents	2
History	4
1.ENVIRONMENT SPECIFICATION	5
2.M9287 (PROFINET NETWORK ADAPTER)	6
2.1.M9287 Specification	6
2.2.9287 Wiring Diagram	7
2.3.M9287 LED Indicator	8
2.3.1.LED Indicator	8
2.3.2.MOD (Module Status LED)	8
2.3.3.NET (Network Status LED)	8
2.3.4.Error (Exchange Data/Traffic Present LED)	8
2.3.5.IOS LED (Extension Module Status LED)	8
2.4.M7001 LED Indicator	9
2.4.1.LED Indicator	9
2.4.2. RUN(RUN Status LED)	9
2.4.3. PRI(Primary Status LED)	9
2.4.4.Error(Error Status LED)	9
2.4.5.Field Power LED (Field Power Status LED)	9
2.5.M9287 Electrical Interface	10
2.5.1.RJ-45 Socket	10
2.5.2.Dip Switch	10
2.5.3.RS232 Port for MODBUS/RTU, Touch Panel or IO-Guide	11
2.6.I/O Process Image Map	12
2.7.Mapping Data into Image Table	12
2.7.1.Discrete Input Module	12
2.7.2.Discrete Output Module	13
2.7.3.Analog Input Module	14
2.7.4.Analog Output Module	15
2.8.Example of Input Process Image (Input Register) Map	16
3.MODBUS INTERFACE	17
3.1.MODBUS Special Register Map	17
3.1.1.Adapter Identification Special Register (0x1000, 4096)	17
3.1.2.Time Special Register (0x1020, 4128)	17
3.1.3.Adapter TCP/IP, Hotswap Special Register (0x1040, 4160)	17
3.1.4.Adapter Information Special Register (0x1100, 4352)	18

3.1.5.Expansion Slot Information Special Resister (0x2000, 8192).....	18
3.2.Supported MODBUS Function Codes.....	21
4.PARAMETER.....	22
4.1.M9287 Parameter.....	22
4.2.M9287 PROFINET IO Characteristics.....	22
4.2.1.Device Identity.....	22
4.2.2.Device Access Point.....	22
4.2.3.Sub-slot of M9287.....	23

History

REV.	PAGES	REMARKS	DATE	Editor
-		Preliminary	2019/8/7	JY BAE
1.01		Vibration, Product changed, Added ATEX certification, M-Series caution	2020/05/20	CW SEO
1.02	24	Modify Firmware Revision	2020/10/29	CW SEO
1.03	12,28	Remove Description pages of Hot Swap Function, Use in Hazardous Environments and Caution(Before using the unit)	2020/12/07	SJ LIM
1.04	7	NA image change	2021/03-04	CW SEO

1. ENVIRONMENT SPECIFICATION

Environmental specification	
Operating Temperature	-25°C~60°C
UL Temperature	-20°C~60°C
Storage Temperature	-40°C~85°C
Relative Humidity	5% ~ 90% non-condensing
Mounting	DIN rail
General specification	
Shock Operating	IEC 60068-2-27
Vibration Resistance	Based on IEC 60068-2-6 DNVGL-CG-0039 : Vibration Class B, 4g
Industrial Emissions	EN 61000-6-4/A11 : 2011
Industrial Immunity	EN 61000-6-2 : 2005
Installation Position	Vertical and horizontal installation is available.
Product Certifications	CE, UL, FCC, ATEX

2. M9287 (PROFINET NETWORK ADAPTER)

2.1. M9287 Specification

Items	Specification
Input Specification	
Adapter Type	Slave node (Profinet), Single
Protocol	Profinet, Modbus RTU
Max. Expansion Module	32 slots
Max. Data Size(Input + Output)	Max 1440 bytes
Max Length Bus Line	Up to 100m from Ethernet Hub/Switch with twisted CAT5 UTP/STP
Max. Nodes	Limited by Profinet Specification.
Baud Rate	100Mbps, Auto-negotiation, Full duplex
Interface Connector	RJ-45 socket * 2pcs
IP-Address Setup	Via Master Device Software
Max. Parameter Size	2048 Bytes (ex : 1 slot = 64 Byte + I/O Parameter Size(Dword size))
Serial Port	RS232 for MODBUS/RTU, Touch Pannel or IOGuide
Serial Configuration (RS232)	Node : 1 (Fixed) Baud Rate : 115200 (Fixed) Data bit : 8 (Fixed) Parity bit : No parity (Fixed) Stop bit : 1 (Fixed)
Indicator	4 LEDs 1 Green/Red, Module Status (MOD) 1 Green, Physical Connection (NET) 1 Green/RED, Network Error (ERROR) 1 Green/Red, Expansion I/O Module Status (IOS) 2 LEDs (each RJ45 Connector) 1 Yellow, Link/Active 1 Green, Not used
Module Location	Starter module left side of M-Series system
General specification (Supplied by M7001)	
UL System Power	Supply voltage : 24Vdc nominal, Class 2
System Power	Supply voltage : 24Vdc nominal Supply voltage range : 15~28.8Vdc Protection : Output current limit, Reverse polarity protection
Power Dissipation	85mA typical @ 24Vdc
Current for I/O Module	2.0A @ 5Vdc (If except for NA, current for I/O module is about 1.7A)
Isolation	System power to internal logic : Non-isolation System power I/O driver : Isolation
UL Field Power	Supply voltage : 24Vdc nominal, Class 2
Field Power	Supply voltage : 24Vdc typical (Max. 28.8Vdc) * Field Power Range is different depending on IO Module series. Refer to IO Module's Specification.
Max. Current Field Power Contact	DC 10A Max
Weight	179g
Module Size	54mm x 110mm x 75mm
Environment Condition	Refer to '1. Environment Specification'

* Class 2, adjacent to voltage rating (30Vmax)

2.2. 9287 Wiring Diagram

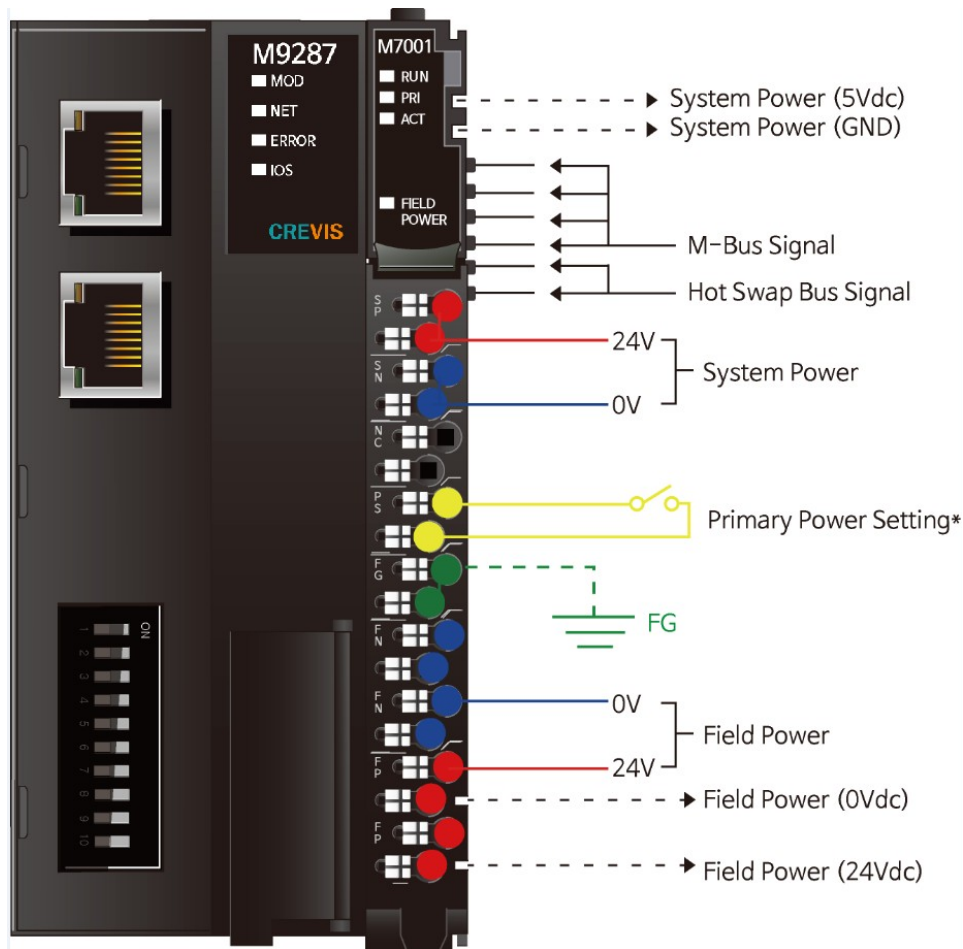

* Primary Power Setting (P.S pin)

- Short the P.S pin to set one of the two M7001 as the primary power.

Pin No.	Signal Description
0	SP System Power, 24V
1	SP System Power, 24V
2	SN System Power, 0V(GND)
3	SN System Power, 0V(GND)
4	NC -----
5	NC -----
6	PS Primary Power Setting
7	PS Primary Power Setting
8	FG F.G
9	FG F.G
10	FN Field Power 0V (GND)
11	FN Field Power 0V (GND)
12	FN Field Power 0V (GND)
13	FN Field Power 0V (GND)
14	FP Field Power 24V
15	FP Field Power 24V
16	FP Field Power 24V
17	FP Field Power 24V

Series No	Through Air	Over Surface	CTI
RTB18C	1.5mm	1.5mm	175≤CTI≤400

Spacings : The following minimum spacing in inches (millimeters) shall be maintained between uninsulated live parts of opposite polarity; and between an uninsulated live part and a grounded part including any mounting surface or exposed metal part.

2.3. M9287 LED Indicator

2.3.1. LED Indicator

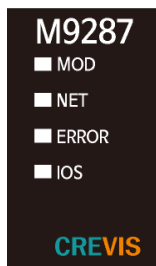

LED No.	LED Function / Description	LED Color
MOD	Module Status	Green/Red
NET	Current communication status	Green
ERROR	Error Status (Profinet)	RED
I/O	Extension Module Status	Green/Red

2.3.2. MOD (Module Status LED)

Status	LED	To indicate
Not Powered	OFF	Power is not supplied to the unit.
Device Operational	Green	The unit is operating in normal condition.
Unrecoverable Fault	Red	The device has an unrecoverable fault. - Memory error or CPU watchdog error.

2.3.3. NET (Network Status LED)

Status	LED	To indicate
No Powered	OFF	No power is supplied to the unit.
Communication	Green	Normal communication.
Communication Ready	Flashing Green	Communication identification.
Invalid Configuration	Flashing Red	DCP Communication error(Invalid Configuration).

2.3.4. Error (Exchange Data/Traffic Present LED)

Status	LED	To indicate
Not Powered	OFF	Device is idle or may not be powered.
Connection error	Red	Communication connection error.
Invalid configuration	Flashing Red	Mismatch I/O Module between Master and Device

* Invalid configuration is compare the I/O module number of setting by the master.

2.3.5. IOS LED (Extension Module Status LED)

Status	LED	To indicate
Not Powered	OFF	Device may not be powered.
Incorrect IO Module	Flashing Red	If Hotswap function is enable, configured module is incorrect.
Internal Bus Connection, Run Exchanging I/O	Green	Exchanging I/O data.
Expansion Configuration Failed	Red	One or more expansion module occurred in fault state. - Detected invalid expansion module ID. - Overflowed Input/Output Size - Too many expansion module - Initialization failure - Communication failure. - Changed expansion module configuration. - Mismatch vendor code between adapter and expansion module.

2.4. M7001 LED Indicator

2.4.1. LED Indicator



LED No.	LED Function / Description	LED Color
RUN	M-Bus Status	Green
PRI	Primary Status	Green
ACT	Active	Green
Field Power	Field Power Enable	Green

2.4.2. RUN(RUN Status LED)

Status	LED	To indicate
Supplied System power	Green	Supplied 5Vdc system power.
No System power	OFF	Not Supplied 5Vdc system power.

2.4.3. PRI(Primary Status LED)

Status	LED	To indicate
Primary Setting	Green	Primary power module.
Not Primary Setting	OFF	Secondary power module or not use redundancy function.

2.4.4. Error(Error Status LED)

Status	LED	To indicate
Main Power Module	Green	When the Power Module is operating in main operation.
Substitution Power Module	OFF	Standby with Substitution Power Module.

2.4.5. Field Power LED (Field Power Status LED)

Status	LED	To indicate
No field power	OFF	Not supplied 24Vdc field power.
Supplied field power	Green	Supplied 24Vdc field power.

2.5. M9287 Electrical Interface

2.5.1. RJ-45 Socket

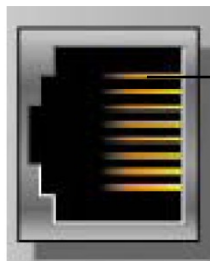

RJ-45	Signal Name	Description
1	TD+	Transmit +
2	TD-	Transmit -
3	RD+	Receive +
4	-	
5	-	
6	RD-	Receive -
7	-	
8	-	
Case	Shield	

2.5.2. Dip Switch

* Set Node 1~99

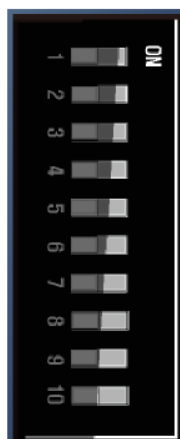

DIP Pole#	Description	
1	Node ID Bit0	Device Name (M9287-XX) - XX must a value between 1~99.
2	Node ID Bit1	
3	Node ID Bit2	
4	Node ID Bit3	
5	Node ID Bit4	
6	Node ID Bit5	
7	Node ID Bit6	
8	Reserve	
9	Reserve	
10	Node ID : Flash Memory Value	

• **When the dip switch is not set to non-zero (1~99):**

If the decimal value of the dip switch is not zero (0), the name of device will be fixed as “M9287-xx” (xx: 1~99). You must put the fixed device name.

• **When the dip switch “10 pole” is set to switch ON:**

M9287 Devices on a PROFINET subnet must have unique names. The device names must satisfy DNS naming conventions. This means that the following rules must be observed:

- Names are limited to a total of 127 characters (letters, numbers, dashes or dots)
 - Any component part (that is, a character string between two dots) of the device name may only be up to 63 characters long.
 - Names cannot contain any special characters such as umlauts, parentheses, underscores, forward or backward slashes, empty spaces, etc. The dash is the only special character allowed.
 - Names must not begin or end with the "-" or "." characters.
 - Names must not have the format n.n.n.n (where n = 0...999).
 - The device name must not start with numbers.
 - If you want to change the IP address in non-volatile memory, please refer to Chapter3. (Editing Ethernet Nodes)
- Device names are assigned to PROFINET IO device when the device is being set up and placed in operation for the first time ("commissioned").
The default name is “M9287-address”.

2.5.3. RS232 Port for MODBUS/RTU, Touch Panel or IO-Guide

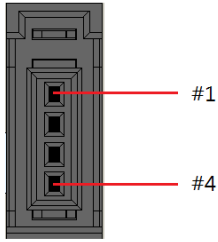

Pin#	Signal Name	Description
1	Reserved	----
2	TXD	RS232 TXD
3	RXD	RS232 RXD
4	GND	RS232 GND

2.6. I/O Process Image Map

An expansion module may have 3 types of data as I/O data, configuration parameter and memory register. The data exchange between network adapter and expansion modules is done via an I/O process image data by M-Series protocol. The following figure shows the data flow of process image between network adapter and expansion modules.

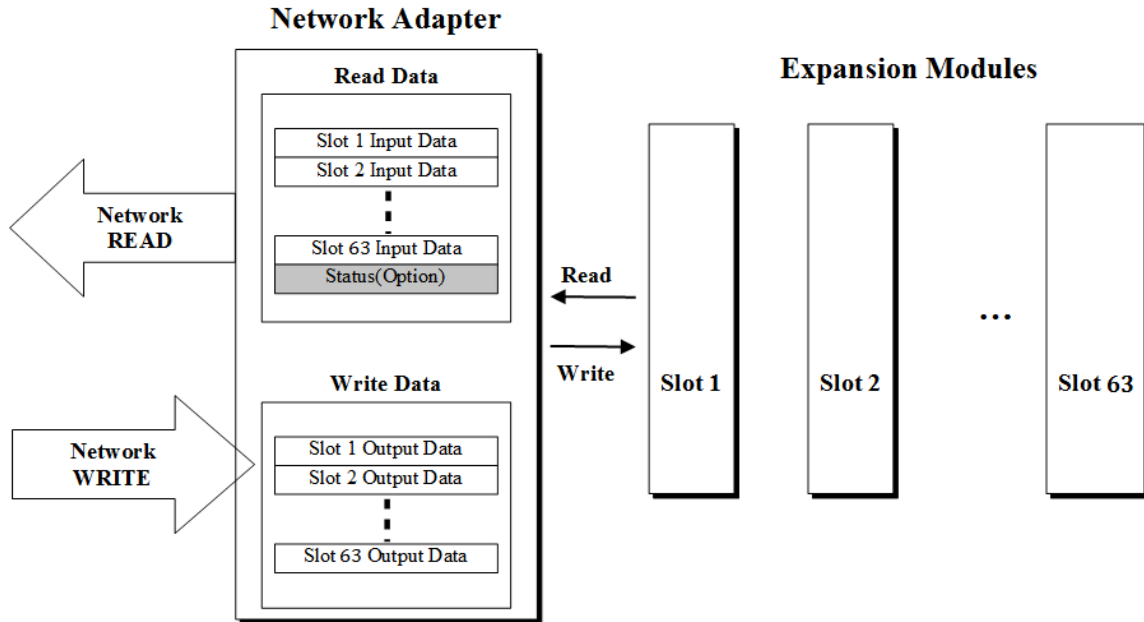

2.7. Mapping Data into Image Table

2.7.1. Discrete Input Module

- 4 Point Input Module

Input Module Data



Input Image Value

Bit No	Bit7	Bit6	Bit5	Bit4	Bit3	Bit2	Bit1	Bit0
Byte 0	Reserved				D3	D2	D1	D0

- 8 Point Input Module

Input Module Data

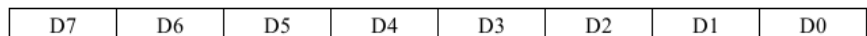

Input Image Value

Bit No	Bit7	Bit6	Bit5	Bit4	Bit3	Bit2	Bit1	Bit0
Byte 0	D7	D6	D5	D4	D3	D2	D1	D0

- 16 Point Input Module

Input Image Value

Bit No	Bit7	Bit6	Bit5	Bit4	Bit3	Bit2	Bit1	Bit0
Byte 0	D7	D6	D5	D4	D3	D2	D1	D0

Input Module Data

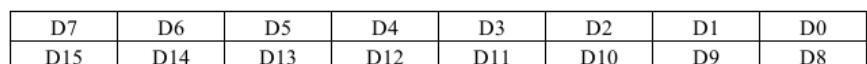

Specification

- 32 Point Input Module

Input Module Data

D7	D6	D5	D4	D3	D2	D1	D0
D15	D14	D13	D12	D11	D10	D9	D8
D23	D22	D21	D20	D19	D18	D17	D16
D31	D30	D29	D28	D27	D26	D25	D24



Input Image Value

Bit No	Bit7	Bit6	Bit5	Bit4	Bit3	Bit2	Bit1	Bit0
Byte 0	D7	D6	D5	D4	D3	D2	D1	D0
Byte 1	D15	D14	D13	D12	D11	D10	D9	D8
Byte 2	D23	D22	D21	D20	D19	D18	D17	D16
Byte 3	D31	D30	D29	D28	D27	D26	D25	D24

2.7.2. Discrete Output Module

- 8 Point Output Module

Output Image Value

Bit No	Bit7	Bit6	Bit5	Bit4	Bit3	Bit2	Bit1	Bit0
Byte 0	D7	D6	D5	D4	D3	D2	D1	D0



Output Module Data

D7	D6	D5	D4	D3	D2	D1	D0
----	----	----	----	----	----	----	----

- 16 Point Output Module

Output Image Value

Bit No	Bit7	Bit6	Bit5	Bit4	Bit3	Bit2	Bit1	Bit0
Byte 0	D7	D6	D5	D4	D3	D2	D1	D0
Byte 1	D15	D14	D13	D12	D11	D10	D9	D8



Output Module Data

D7	D6	D5	D4	D3	D2	D1	D0
D15	D14	D13	D12	D11	D10	D9	D8

- 32 Point Output Module

Output Image Value

Bit No	Bit7	Bit6	Bit5	Bit4	Bit3	Bit2	Bit1	Bit0
Byte 0	D7	D6	D5	D4	D3	D2	D1	D0
Byte 1	D15	D14	D13	D12	D11	D10	D9	D8
Byte 2	D23	D22	D21	D20	D19	D18	D17	D16
Byte 3	D31	D30	D29	D28	D27	D26	D25	D24



Output Module Data

D7	D6	D5	D4	D3	D2	D1	D0
D15	D14	D13	D12	D11	D10	D9	D8
D23	D22	D21	D20	D19	D18	D17	D16
D31	D30	D29	D28	D27	D26	D25	D24

2.7.3. Analog Input Module

- 4 Channel Analog Input Module

Input Module Data	Analog Input Ch0
	Analog Input Ch1
	Analog Input Ch2
	Analog Input Ch3



Input Image Value	Bit No	Bit7	Bit6	Bit5	Bit4	Bit3	Bit2	Bit1	Bit0
	Byte 0	Analog Input Ch0 low byte							
	Byte 1	Analog Input Ch0 high byte							
	Byte 2	Analog Input Ch1 low byte							
	Byte 3	Analog Input Ch1 high byte							
	Byte 4	Analog Input Ch2 low byte							
	Byte 5	Analog Input Ch2 high byte							
	Byte 6	Analog Input Ch3 low byte							
	Byte 7	Analog Input Ch3 high byte							

- 8 Channel Analog Input Module

Input Module Data	Analog Input Ch0
	Analog Input Ch1
	Analog Input Ch2
	Analog Input Ch3
	Analog Input Ch4
	Analog Input Ch5
	Analog Input Ch6
	Analog Input Ch7



Input Image Value	Bit No	Bit7	Bit6	Bit5	Bit4	Bit3	Bit2	Bit1	Bit0
	Byte 0	Analog Input Ch0 low byte							
	Byte 1	Analog Input Ch0 high byte							
	Byte 2	Analog Input Ch1 low byte							
	Byte 3	Analog Input Ch1 high byte							
	Byte 4	Analog Input Ch2 low byte							
	Byte 5	Analog Input Ch2 high byte							
	Byte 6	Analog Input Ch3 low byte							
	Byte 7	Analog Input Ch3 high byte							
	Byte 8	Analog Input Ch0 low byte							
	Byte 9	Analog Input Ch0 high byte							
	Byte 10	Analog Input Ch1 low byte							
	Byte 11	Analog Input Ch1 high byte							
	Byte 12	Analog Input Ch2 low byte							
	Byte 13	Analog Input Ch2 high byte							
	Byte 14	Analog Input Ch3 low byte							
	Byte 15	Analog Input Ch3 high byte							

Specification

2.7.4. Analog Output Module

- 4 Channel Analog Input Module

Output Image Value	Bit No	Bit7	Bit6	Bit5	Bit4	Bit3	Bit2	Bit1	Bit0
	Byte 0	Analog Output Ch0 low byte							
	Byte 1	Analog Output Ch0 high byte							
	Byte 2	Analog Output Ch1 low byte							
	Byte 3	Analog Output Ch1 high byte							
	Byte 4	Analog Output Ch2 low byte							
	Byte 5	Analog Output Ch2 high byte							
	Byte 6	Analog Output Ch3 low byte							
	Byte 7	Analog Output Ch3 high byte							



Output Module Data	Analog Output Ch0
	Analog Output Ch1
	Analog Output Ch2
	Analog Output Ch3

- 8 Channel Analog Input Module

Output Image Value	Bit No	Bit7	Bit6	Bit5	Bit4	Bit3	Bit2	Bit1	Bit0
	Byte 0	Analog Output Ch0 low byte							
	Byte 1	Analog Output Ch0 high byte							
	Byte 2	Analog Output Ch1 low byte							
	Byte 3	Analog Output Ch1 high byte							
	Byte 4	Analog Output Ch2 low byte							
	Byte 5	Analog Output Ch2 high byte							
	Byte 6	Analog Output Ch3 low byte							
	Byte 7	Analog Output Ch3 high byte							
	Byte 8	Analog Output Ch4 low byte							
	Byte 9	Analog Output Ch4 high byte							
	Byte 10	Analog Output Ch5 low byte							
	Byte 11	Analog Output Ch5 high byte							
	Byte 12	Analog Output Ch6 low byte							
	Byte 13	Analog Output Ch6 high byte							
	Byte 14	Analog Output Ch7 low byte							
Byte 15	Analog Output Ch7 high byte								



Output Module Data	Analog Output Ch0
	Analog Output Ch1
	Analog Output Ch2
	Analog Output Ch3
	Analog Output Ch4
	Analog Output Ch5
	Analog Output Ch6
	Analog Output Ch7

Specification

2.8. Example of Input Process Image (Input Register) Map

Input image data depends on slot position and expansion slot data type. Input process image data is only ordered by expansion slot position .

- For example slot configuration

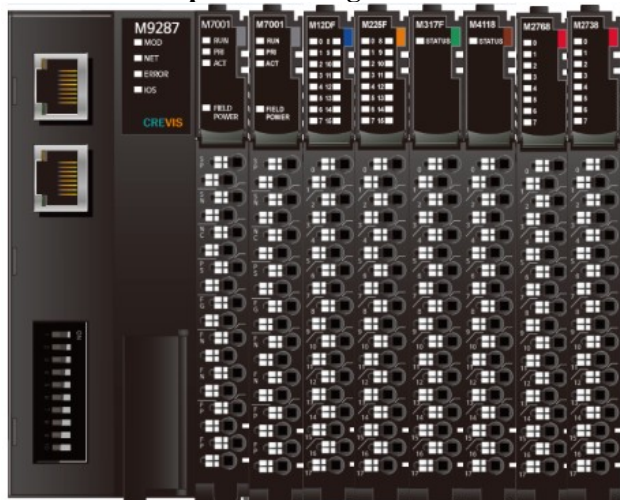

Slot Address	Module Description
#0	ProfiNet Adapter
#1	Power Input
#2	Power Input
#3	16-discrete input
#4	16-discrete output
#5	16-analog input
#6	8-analog output
#7	8-discrete output
#8	8-discrete output

- Input Process Image

Byte	Slot #	Bit 7	Bit 6	Bit 5	Bit 4	Bit 3	Bit 2	Bit 1	Bit 0
Read Byte 0	Slot 1	Power Input(PRI)							
Read Byte 1	Slot 2	Power Input (SEC)							
Read Byte 2	Slot 3	Discrete Input 16 Point low byte							
Read Byte 3		Discrete Input 16 Point high byte							
Read Byte 4	Slot 5	Analog Input Ch0 low byte							
Read Byte 5		Analog Input Ch0 high byte							
Read Byte 6		Analog Input Ch1 low byte							
Read Byte 7		Analog Input Ch1 high byte							
Read Byte 8		Analog Input Ch2 low byte							
Read Byte 9		Analog Input Ch2 high byte							
Read Byte 10		Analog Input Ch3 low byte							
Read Byte 11		Analog Input Ch3 high byte							
Read Byte 12		Analog Input Ch4 low byte							
Read Byte 13		Analog Input Ch4 high byte							

- Output Process Image

Byte	Slot #	Bit 7	Bit 6	Bit 5	Bit 4	Bit 3	Bit 2	Bit 1	Bit 0
Write Byte 0	Slot 4	Discrete Output 16 Point low byte							
Write Byte 1		Discrete Output 16 Point high byte							
Write Byte 2	Slot 6	Analog Output Ch0 low byte							
Write Byte 3		Analog Output Ch0 high byte							
Write Byte 4		Analog Output Ch1 low byte							
Write Byte 5		Analog Output Ch1 high byte							
Write Byte							
Write Byte							
Write Byte 14		Analog Output Ch6 low byte							
Write Byte 15		Analog Output Ch6 high byte							
Write Byte 16		Analog Output Ch7 high byte							
Write Byte 17		Analog Output Ch7 low byte							
Write Byte 18	Slot 7	Discrete Output 8 Point byte							
Write Byte 19	Slot 8	Discrete Output 8 Point byte							

3. MODBUS INTERFACE

3.1. MODBUS Special Register Map

The special register map can be accessed by function code 3, 4, 6 and 16. Also the special register map must be accessed by read/write of every each address (one address).

3.1.1. Adapter Identification Special Register (0x1000, 4096)

Address	Access	Type, Size	Description
0x1000(4096)	Read	1word	Vendor ID = 0x0140(320), Crevis. Co., Ltd.
0x1001(4097)	Read	1word	Device type = 0x000C, Network Adapter
0x1002(4098)	Read	1word	Product Code = 0xA080
0x1003(4099)	Read	1word	Firmware revision, if 0x0101, revision 1.01
0x1004(4100)	Read	2word	Product unique serial number
0x1005(4101)	Read	String upto 34byte	Product name string (ASCII) “M9287,PROFINET,MBUS”
0x1006(4102)	Read	1word	Sum check of EEPROM
0x1010(4112)	Read	2word	Firmware release date
0x1011(4113)	Read	2word	Product manufacturing inspection date
0x101E(4126)	Read	7word - 1word - 1word - 1word - 1word - 1word - 2word	Composite Id of following address * RTU mode 0x1100(4352), Modbus RS232 Node. (Fixed 0x0001) 0x1000(4096), Vendor ID 0x1001(4097), Device type 0x1002(4098), Product code 0x1003(4099), Firmware revision 0x1004(4100), Product serial number

String Type consists of valid string length (first 1word) and array of characters

3.1.2. Time Special Register (0x1020, 4128)

Address	Access	Type, Size	Description
0x1028(4136)	Read	1word	IO update time, main loop time. (1usec unit), General 1msec

* When setting the PLC update time, it is recommended to set at least 2ms above the 0x1028 register settingvalue.

3.1.3. Adapter IP/MAC Special Register (0x1040, 4160)

Address	Access	Type, Size	Description
0x1050(4176)	Read/Write	2word	IP address. If 192.168.123.1, then 0xA8C0, 0x017B. After update this value, IP address, Subnet mask and Gateway are applied as new one.
0x1051(4177)	Read/Write	2word	Subnet mask. If 255.255.255.0, then 0xFFFF, 0x00FF.
0x1052(4178)	Read/Write	2word	Gateway. If 192.168.123.254, then 0xA8C0, 0xFE7B.
0x1053(4179)	Read	3word	Ethernet physical address (MAC-ID). If 11-22-33-44-55-66, then 0x2211, 0x4433, 0x6655.

* Power off and then power on, this value is applied.

Specification

3.1.4. Adapter Hotswap Register (0x1060, 4192)

Address	Access	Type, Size	Description
0x1060(4192)	Read/Write	1 word	Hot swap status 0 : Enable 1 : Disable
0x1062(4194)	Read	1 word	Error slot detection 0 : No error slot 1 : Error slot detection
0x1063(4195)	Read	4word	Error slot location, 8x8 bit

* 0x1062 and 0x1063 functions are only available if hot swap(0x1060) is enabled.

3.1.5. Adapter Information Special Register (0x1100, 4352)

Address	Access	Type, Size	Description																				
0x1102(4354)	Read	1 word	Start address of input image word register. =0x0000																				
0x1103(4355)	Read	1 word	Start address of output image word register. =0x0800																				
0x1104(4356)	Read	1 word	Size of input image word register.																				
0x1105(4357)	Read	1 word	Size of output image word register.																				
0x1106(4358)	Read	1 word	Start address of input image bit. = 0x0000																				
0x1107(4359)	Read	1 word	Start address of output image bit. =0x1000																				
0x1108(4360)	Read	1 word	Size of input image bit.																				
0x1109(4361)	Read	1 word	Size of output image bit.																				
0x110A(4362)	Read	1 word	Update time for cyclic data change (same as 0x1028)																				
0x110E(4366)	Read	upto 33word	Expansion slot's M-number including First 1word is adapter's number, if M9287, then 0x9287																				
0x1110(4368)	Read	1 word	Number of expansion slot																				
0x1113(4371)	Read	upto 33word	Expansion slot Module Id. First 1word is adapter's product code.																				
0x1119(4377)	Read	1 word	Hi byte is ModBus status, low byte is internal status. Zero value means 'no error'. <table border="1" style="width: 100%; border-collapse: collapse;"> <thead> <tr> <th style="width: 50%;">ModBus Status</th> <th style="width: 50%;">Internal bus status(M-Bus)</th> </tr> </thead> <tbody> <tr> <td>0x00 : No Error</td> <td>0x01 : INIT_STATE</td> </tr> <tr> <td>0x01 : ERR_DIP_SWITCH</td> <td>0x02 : IDLE_STATE</td> </tr> <tr> <td>0x40 : ERR_CRC_LRC</td> <td>0x03 : RUN_STATE</td> </tr> <tr> <td>0x80 : ERR_WATCHDOG</td> <td>0x04 : STOP_STATE</td> </tr> <tr> <td></td> <td>0x05 : FAULT_STATE</td> </tr> <tr> <td></td> <td>0x06 : RESET_STATE</td> </tr> <tr> <td></td> <td>0x07 : CRCERR_STATE</td> </tr> <tr> <td></td> <td>0x08 : PAUSE_STATE</td> </tr> <tr> <td></td> <td>0x80* : At Hot swap mode expansion module error</td> </tr> </tbody> </table>	ModBus Status	Internal bus status(M-Bus)	0x00 : No Error	0x01 : INIT_STATE	0x01 : ERR_DIP_SWITCH	0x02 : IDLE_STATE	0x40 : ERR_CRC_LRC	0x03 : RUN_STATE	0x80 : ERR_WATCHDOG	0x04 : STOP_STATE		0x05 : FAULT_STATE		0x06 : RESET_STATE		0x07 : CRCERR_STATE		0x08 : PAUSE_STATE		0x80* : At Hot swap mode expansion module error
ModBus Status	Internal bus status(M-Bus)																						
0x00 : No Error	0x01 : INIT_STATE																						
0x01 : ERR_DIP_SWITCH	0x02 : IDLE_STATE																						
0x40 : ERR_CRC_LRC	0x03 : RUN_STATE																						
0x80 : ERR_WATCHDOG	0x04 : STOP_STATE																						
	0x05 : FAULT_STATE																						
	0x06 : RESET_STATE																						
	0x07 : CRCERR_STATE																						
	0x08 : PAUSE_STATE																						
	0x80* : At Hot swap mode expansion module error																						
0x111D(4381)	Read	1 word	Adapter M-Series Revision.																				

* After the system is reset, the new "Set Value" action is applied.

** If the slot location is changed, set default value automatically (all expansion slot are live).

Specification

3.1.6. Expansion Slot Information Special Resister (0x2000, 8192)

Each expansion slot has 0x20(32) address offset and same information structure.

Slot#1	0x2000(8192)~0x201F(8223)	Slot#2	0x2020(8224)~0x203F(8255)
Slot#3	0x2040(8256)~0x205F(8287)	Slot#4	0x2060(8288)~0x207F(8319)
Slot#5	0x2080(8320)~0x209F(8351)	Slot#6	0x20A0(8352)~0x20BF(8383)
Slot#7	0x20C0(8384)~0x20DF(8415)	Slot#8	0x20E0(8416)~0x20FF(8447)
Slot#9	0x2100(8448)~0x211F(8479)	Slot#10	0x2120(8480)~0x213F(8511)
Slot#11	0x2140(8512)~0x215F(8543)	Slot#12	0x2160(8544)~0x217F(8575)
Slot#13	0x2180(8576)~0x219F(8607)	Slot#14	0x21A0(8608)~0x21BF(8639)
Slot#15	0x21C0(8640)~0x21DF(8671)	Slot#16	0x21E0(8672)~0x21FF(8703)
Slot#17	0x2200(8704)~0x221F(8735)	Slot#18	0x2220(8736)~0x223F(8767)
Slot#19	0x2240(8768)~0x225F(8799)	Slot#20	0x2260(8800)~0x227F(8831)
Slot#21	0x2280(8832)~0x229F(8863)	Slot#22	0x22A0(8864)~0x22BF(8895)
Slot#23	0x22C0(8896)~0x22DF(8927)	Slot#24	0x22E0(8928)~0x22FF(8959)
Slot#25	0x2300(8960)~0x231F(8991)	Slot#26	0x2320(8992)~0x233F(9023)
Slot#27	0x2340(9024)~0x235F(9055)	Slot#28	0x2360(9056)~0x237F(9087)
Slot#29	0x2380(9088)~0x239F(9119)	Slot#30	0x23A0(9120)~0x23BF(9151)
Slot#31	0x23C0(9152)~0x23DF(9183)	Slot#32	0x23E0(9184)~0x23FF(9215)
Slot#33	0x2400(9216)~0x241F(9247)	Slot#34	0x2420(9248)~0x243F(9279)
.....			
Slot#63	0x27C0(10176)~0x27DF(10207)		

Address Offset	Expansion Slot#1	Expansion Slot#2	Expansion Slot#3	Expansion Slot#4	Expansion Slot#63
+ 0x00(+0)	0x2000(8192)	0x2020(8224)	0x2040(8256)	0x2060(8288)	0x27C0(10176)
+ 0x01(+1)	0x2001(8193)	0x2021(8225)	0x2041(8257)	0x2061(8289)	0x27C1(10177)
+ 0x02(+2)	0x2002(8194)	0x2022(8226)	0x2042(8258)	0x2062(8290)	0x27C2(10178)
+ 0x03(+3)	0x2003(8195)	0x2023(8227)	0x2043(8259)	0x2063(8291)	0x27C3(10179)
+ 0x04(+4)	0x2004(8196)	0x2024(8228)	0x2044(8260)	0x2064(8292)	0x27C4(10180)
+ 0x05(+5)	0x2005(8197)	0x2025(8229)	0x2045(8261)	0x2065(8293)	0x27C5(10181)
+ 0x06(+6)	0x2006(8198)	0x2026(8230)	0x2046(8262)	0x2066(8294)	0x27C6(10182)
+ 0x07(+7)	0x2007(8199)	0x2027(8231)	0x2047(8263)	0x2067(8295)	0x27C7(10183)
+ 0x08(+8)	0x2008(8200)	0x2028(8232)	0x2048(8264)	0x2068(8296)	0x27C8(10184)
+ 0x09(+9)	0x2009(8201)	0x2029(8233)	0x2049(8265)	0x2069(8297)	0x27C9(10185)
+ 0x0A(+10)	0x200A(8202)	0x202A(8234)	0x204A(8266)	0x206A(8298)	0x27CA(10186)
+ 0x0B(+11)	0x200B(8203)	0x202B(8235)	0x204B(8267)	0x206B(8299)	0x27CB(10187)
+ 0x0C(+12)	0x200C(8204)	0x202C(8236)	0x204C(8268)	0x206C(8300)	0x27CC(10188)
+ 0x0D(+13)	0x200D(8205)	0x202D(8237)	0x204D(8269)	0x206D(8301)	0x27CD(10189)
+ 0x0E(+14)	0x200E(8206)	0x202E(8238)	0x204E(8270)	0x206E(8302)	0x27CE(10190)
+ 0x0F(+15)	0x200F(8207)	0x202F(8239)	0x204F(8271)	0x206F(8303)	0x27CF(10191)
+ 0x10(+16)	0x2010(8208)	0x2030(8240)	0x2050(8272)	0x2070(8304)	0x27D0(10192)
+ 0x11(+17)	0x2011(8209)	0x2031(8241)	0x2051(8273)	0x2071(8305)	0x27D1(10193)
+ 0x12(+18)	0x2012(8210)	0x2032(8242)	0x2052(8274)	0x2072(8306)	0x27D2(10194)
+ 0x13(+19)	0x2013(8211)	0x2033(8243)	0x2053(8275)	0x2073(8307)	0x27D3(10195)
+ 0x14(+20)	0x2014(8212)	0x2034(8244)	0x2054(8276)	0x2074(8308)	0x27D4(10196)
+ 0x15(+21)	0x2015(8213)	0x2035(8245)	0x2055(8277)	0x2075(8309)	0x27D5(10197)
+ 0x16(+22)	0x2016(8214)	0x2036(8246)	0x2056(8278)	0x2076(8310)	0x27D6(10198)
+ 0x17(+23)	0x2017(8215)	0x2037(8247)	0x2057(8279)	0x2077(8311)	0x27D7(10199)
+ 0x18(+24)	0x2018(8216)	0x2038(8248)	0x2058(8280)	0x2078(8312)	0x27D8(10200)
+ 0x19(+25)	0x2018(8217)	0x2038(8249)	0x2058(8281)	0x2078(8313)	0x27D9(10201)
+ 0x1A(+26)	0x201A(8218)	0x203A(8250)	0x205A(8282)	0x207A(8314)	0x27DA(10202)
+ 0x1B(+27)	0x201B(8219)	0x203B(8251)	0x205B(8283)	0x207B(8315)	0x27DB(10203)
+ 0x1C(+28)	0x201C(8220)	0x203C(8252)	0x205C(8284)	0x207C(8316)	0x27DC(10204)
+ 0x1D(+29)	0x201D(8221)	0x203D(8253)	0x205D(8285)	0x207D(8317)	0x27DD(10205)
+ 0x1E(+30)	0x201E(8222)	0x203E(8254)	0x205E(8286)	0x207E(8318)	0x27DE(10206)
+ 0x1F(+31)	0x201F(8223)	0x203F(8255)	0x205F(8287)	0x207F(8319)	0x27DF(10207)

Address Offset	Access	Type, Size	Description
+ 0x02(+2) **	Read	1 word	Input start register address of input image word this slot.
+ 0x03(+3) **	Read	1 word	Input word's bit offset of input image word this slot.
+ 0x04(+4) **	Read	1 word	Output start register address of output image word this slot.
+ 0x05(+5) **	Read	1 word	Output word's bit offset of output image word this slot.
+ 0x06(+6) **	Read	1 word	Input bit start address of input image bit this slot.
+ 0x07(+7) **	Read	1 word	Output bit start address of output image bit this slot.
+ 0x08(+8) **	Read	1 word	Size of input bit this slot
+ 0x09(+9) **	Read	1 word	Size of output bit this slot
+ 0x0A(+10)**	Read	n word	Read input data this slot
+ 0x0B(+11)**	Read/Write	n word	Read/write output data this slot
+ 0x0E(+14)	Read	1 word	M-number, if M1238, returns 0x1238
+ 0x0F(+15)	Read	String upto 72byte	First 1word is length of valid character string. If M1238, returns "00 1E 52 54 2D 31 32 33 38 2C 20 38 44 49 2C 20 32 34 56 64 63 2C 20 55 6E 69 76 65 72 73 61 6C 00 00" Valid character size = 0x001E =30 characters, "M1238, 8DI, 24Vdc, Universal"
+ 0x10(+16)	Read	1 word	Size of configuration parameter byte
+ 0x11(+17)**	Read/Write	n word	Read/write Configuration parameter data, up to 8byte. Refer to A.2 ***
+ 0x17(+23)	Read	2word	Firmware Revision ex) 0x00010010 (Major revision 1 /Minor revision 16, Rev 1.016)
+ 0x19(+25)	Read	2word	Firmware release date.

* After the system is reset, the new "Set Value" action is applied.

** Nothing of output, input, memory or configuration parameter corresponding slot returns Exception 02.

3.2. Supported MODBUS Function Codes

MODBUS Reference Documents

<http://www.modbus.org>

MODBUS Tools

<http://www.modbustools.com>, modbus poll

<http://www.win-tech.com>, modscan32

4. PARAMETER

4.1. M9287 Parameter

Parameter	Setting	Description
Word data type	All type	Little Endian format(LSB-MSB)
Stop action	Clear output image to 0 *	All outputs are set to 0.
	Hold last valid output image	All outputs are remain the last value.
Hotswap Disable	Disable	1
	Enable	0

* : Default setting

4.2. M9287 PROFINET IO Characteristics

4.2.1. Device Identity

Item	Value
Vendor	CREVIS
Vendor ID	0x0140
Product family	CREVIS FnIO System
Device ID	0xA080
Details	M9287 PROFINET IO Device

4.2.2. Device Access Point

Item	Value
Module Ident Number	0x0000A080
Details	M9287 PROFINET IO Device
Vendor Name	CREVIS
Order Number	M9287
Category	CREVIS PROFINET I/O
Software Version	V1.0
Hardware Version	V1.0
Maximal Input Length	1440 Bytes
Maximal Output Length	1440 Bytes
Physical Slots	0..32
Minimal Device Interval	4msec
Based on	portStack
DNS Compliant Name	M9287-xx
Supports Extended Assignment of IP Address	No
Fixed in Slots	0
Instance Field of the Object UUID	1
Supports Multiple Write	Yes

Requires IOPS/IOCS	Yes
Requires Engineering tool which supports at least GSDML Version	V2.32

4.2.3. Sub-slot of M9287

Item	Value
Sub-slot Number	Sub-slot Label
32768 (0x8000)	X1
32769 (0x8001)	P1

Sub-module								
Sub-module Ident Number	0x00000001							
M9287 Parameters (Index : 1, Length : 3Bytes, Transfer sequence : 0)								
Byte Offset	Data							
0	0x00, 0x00							
Name of Parameter	Data Type	Byte Offset	Bit Offset	Bit Length	Default value	Value Range	Changeable	Visible
Word data format	Bit Area	0	0	1	MOTOROLA	0..1	Yes	Yes
Stop action	Bit Area	1	0	1	Clear output images to 0	0..1	Yes	Yes
Hotswap Disable	Bit Area	2	0	1	Enable	0..1	Yes	Yes
Interface : M9287								
Sub-module Ident Number					0x0002			
Sub-slot Number					32768 (0x8000)			
Supports Real time Class					Class 1			
Supports Isochronous Mode					No			
Number of Additional Input CRs					0			
Number of Additional Output CRs					0			
Number of Additional Multicast Provider CRs					0			
Number of Multicast Consumer CRs					0			
Supported Send-clock Factors (Base 31.25us)					32 64 128			
Supported Reduction Ratios					1 2 4 8 16 32 64 128 256 512			
Port 1 : Port 1								
Sub-module Ident Number					0x0003			
Sub-slot Number					32769 (0x8001)			
MAU Type					100BASETX			